



Submersible Sand Pump

Type EHS

APPLICATIONS

- Drainage at civil engineering work and building construction site
- Drainage transfer from excavation work of earth & sand
- Collection of sand and gravel
- Drainage of rolling scale pit in ironworks
- Transfer of muddy water
- Dredge of sand and sludge from setting chamber

FEATURES

- Stirring impeller, ensures sand water can be effectively discharged.
- High resistance material against wear, ensures superior durability performance.
- Simple construction for easy maintenance.
- Built-in motor protector prevents motor from burn-out by excessive load/restraint/open phase operation.

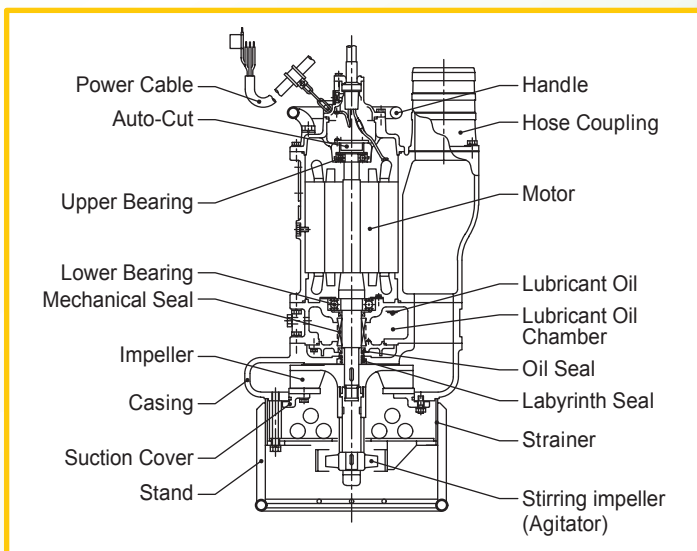

PERFORMANCE CHART

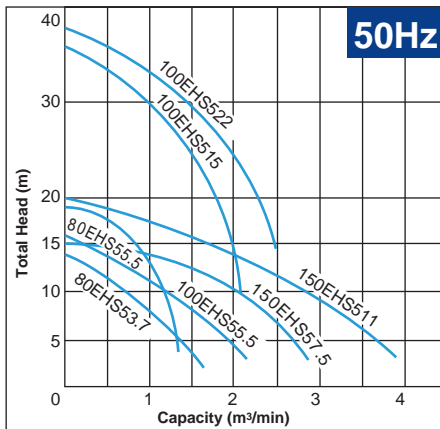

Model	Nominal diameter (mm)	Output (kW)	Ph/Hz/V	Total Head (m)	Capacity (m³/min)	Outer dimension (mm)		Weight (kg)
						Max. diameter	Height	
80EHS53.7	80	3.7	3Ph/50Hz/ 380-415V	10	0.8	410	811	110
80EHS55.5	80	5.5		15	0.8	410	811	119
100EHS55.5	100	5.5		10	1.3	410	811	119
150EHS57.5	150	7.5		10	2.0	515	840	200
150EHS511	150	11		14	2.0	541	1026	240
100EHS515	100	15		27	1.3	530	1300	350
100EHS522	100	22		30	1.5	540	1350	420

SPECIFICATIONS

Item	kW	Size 80 3.7kW	Size 80 5.5kW	Size 100 5.5kW	Size 150 7.5kW	Size 150 11kW	Size 100 15kW	Size 100 22kW	
Liquid handled	Liquid (Note 1)	Spring water from ground, Earth & sand water							
	Diameter of solid matter	22mm and below		25mm and below	35mm and below		18mm and below		
	Density of earth/sand	3% and below (volume)							
	Liquid temperature	0 - 40°C							
	pH	6.5 - 8.0							
Max. pump submergence		30m							
Pump	Construction	Impeller	Semi-open						
		Shaft seal	Double mechanical seal						
		Bearings	Sealed ball bearings					Angular ball bearings	
		Stirring method	Stirring impeller					Forced stirring impeller	
	Material	Impeller	High chrome cast iron						
		Casing	FC250					FCD500	
		Stirring impeller	High chrome cast iron					High chrome cast iron (hardening)	
Shaft seal (Mechanical seal)	Motor side	SiC/SiC				Ceramic/Copper alloy			
	Liquid side	SiC/SiC				Tungsten carbide			
Elastomer		NBR							
Sealed liquid at shaft seal		Turbine oil VG32							
Motor (Note 2) (Note 3)	Type, Pole, Insulation class	Dry type submersible, 4pole, class B			Dry type submersible, 4pole, class F	Dry type submersible, 4pole, class B	Dry type submersible, 4pole, class F		
	Phase, Voltage	Three phase, 380-415V							
	Built-in protector	Auto-cut						Miniature thermal protector	
	Material	Frame	FC200						
		Shaft	SUS420J1					SUS420J2	
Cable		2PNCT			2PNCT (with cloth for reinforcement)				
Cooling method		Semi-inner type							
Type of connection		Hose coupling or flange						Center flange	

Note 1: Do not apply for oil, sea water, organic solvent etc. Pump may be damaged, and may cause electric leakage and electric shock.

Note 2: Ask Ebara about inverter operation.

Note 3: Voltage fluctuation 360<VOL≤420, Frequency fluctuation +/- 1% or less, Simultaneous fluctuation of voltage and frequency 10% or less for sum of absolute value of both. However, in any case, motor characteristics and temperature rise etc. shall not be in accordance with rated value.

Remarks: Do not install under environment of corrosive gas or volatile gas or steam.

Standard accessory

- 1 pc. of Hose coupling or flange (fixed with pump) for 15kW and below
- 1 pc. of Center flange (fixed with pump) for 22kW
- 10m of Submersible cable (fixed with pump) for 11kW and below
- 15m of Submersible cable (fixed with pump) for 15kW and above

* Dimensional details are provided for reference only.

* All specifications are subject to change without prior notice.



EBARA Pumps Malaysia Sdn Bhd
 6, Jalan TP3, UEP Subang Jaya Industrial Park,
 47620 Subang Jaya, Selangor, Malaysia.
 Tel : 03-8023 6622 Fax : 03-8023 9355
 Email : sales@ebara.com.my
 Website : www.ebara.com.my



Authorised dealer: