



EBARA

PROCESS PUMP

Single Stage, Single Suction, Centerline Supported

CS1310EL

Model

UCW

API 610



API 682

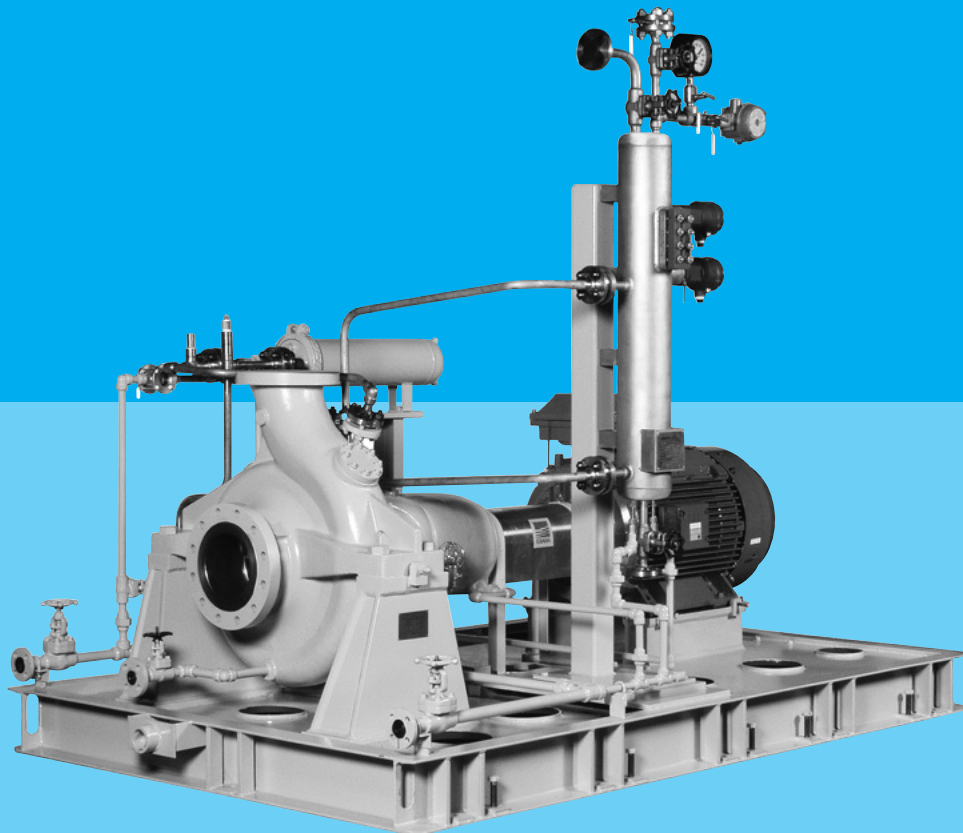

PROCESS PUMP

Single Stage, Single Suction, Centerline Supported

Model

UCW

API 610

Baro®

API 682

EBARA MODEL UCW PROCESS PUMPS of single stage, single suction, centerline supported, horizontal design have been widely used in petroleum refineries, the petrochemical industry and other chemical industries for the past few

years. Many improvements have been recently made on this pump to enhance its performance. Our modern tape controlled machines in conjunction with advanced quality control procedures insure that these pumps meet our high manufacturing

standards. Unique design of this high performance pump provides for superior and extended low-cost operation.

Applications

- Petroleum Refineries
- The Petrochemical Industry
- Other Chemical Industries

Ratings

Capacities	To 1920m ³ /h (8450 USGPM)
Heads	To 380 m (1250 ft)
Max. working pressures	Consistant with the pressure ratings of ANSI Class 300 flanges as a standard. Higher pressure ratings are available.
Rotation	Clockwise viewed from coupling end
Impeller	Enclosed
Temperatures	-100°C to 450°C (-150°F to 850°F)
Flanges	ANSI Class 300 as standard
Nozzles	End-Top/Top-Top
Stuffing box	Suitable for conventional packing & mechanical seal

Features

- Centerline supported heavy duty design.
- Back pull-out casing.
- Full compliance with API 610 and API 682 specifications.
- All components have been designed for maximum parts interchangeability.
- Flexibility of design handles wide range of liquids.
- All sizes stocked for fast shipment.
- Low NPSH performance.

Designations

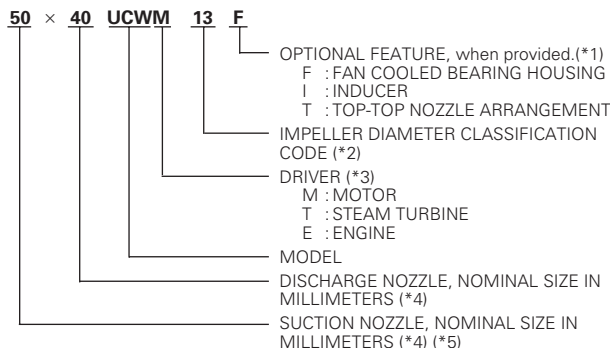

Notes:

- (*1) When two features are involved, the codes are in alphabetical order.
- (*2) The letters "Y" and "Z" following the impeller diameter classification code indicate different casing and impeller designs. To give an example, 150 × 100 UCWM 40Y, 150 × 100 UCWM 40Z and 150 × 100 UCWM 40Z have different casing and impeller designs from one another.
- (*3) When a step up or step down gear is provided, the code letter "G" is added between model and driver. For example, 150 × 100 UCWGM means that the pump is driven by an electric motor through a separate gear.
- (*4) When suction and discharge nozzles are identical, they shall not be duplicated, i.e. 200 UCWM 20 is the correct designation in lieu of 200 × 200 UCWM 20.
- (*5) When an inducer is provided a larger size nozzle is employed.

Construction

End-Top

Shaft Sealing: Mechanical seals are available from any mechanical seal manufacturer. API 682 seal is applicable.

Casing: The volute type casing is designed to maintain high efficiency over long periods of wear. The top centerline discharge connection makes the pump self venting.

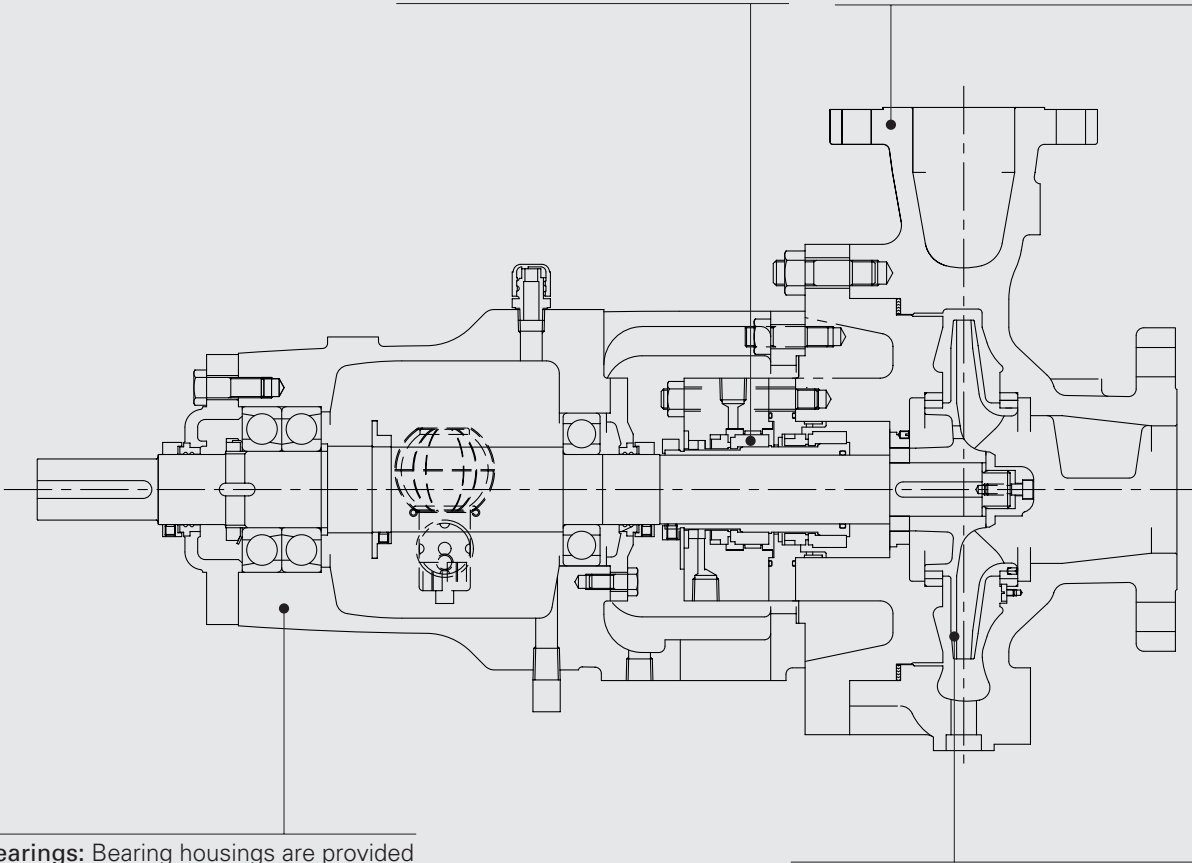

Bearings: Bearing housings are provided with single-row radial and dual single-row, back to back, angular contact thrust bearings. Standard lubrication system is an integral splash type with an oil flinger. Housing seals permit all weather operation.

Impeller: Enclosed impellers are designed for maximum efficiency and minimum required NPSH over a wide range of capacities. Balance holes minimize axial thrust. An inducer is available as an option.

Metallurgy

Part Name	Materials JIS / ASTM-AISI				
	C. Steel	C. Steel	12% Cr. Steel	304 S. Steel	316 S. Steel
Casing	SCPH2/A216WCB	SCPL1/A352LCB	SCS1/CA15 or CA6NM	SCS13A/A743CF8	SCS14A/A743CF8M
Impeller	SCS1/CA15 or CA6NM	SCS13A/A743CF8	SCS1/CA15 or CA6NM	SCS13A/A743CF8	SCS14A/A743CF8M
Impeller Wear Ring	SUS420J2/AISI420	SUS304/AISI304	SUS420J2/AISI420	SUS304/AISI304	SUS316/AISI316
Shaft	SCM440/AISI4140	SUS304/ANSI304	SUS403 or 420J1/AISI420	SUS304/AISI304	SUS316/AISI316
Case Wear Ring	SUS403 or 420J1/AISI420	SUS304/AISI304	SUS403 or 420J1/AISI420	SUS304/AISI304	SUS316/AISI316
Packing Sleeve	SUS420J2/AISI420	SUS304/AISI304	SUS420J2/AISI420	SUS304/AISI304	SUS316/AISI316
Mechanical Seal Sleeve	SUS316/AISI316	SUS316/AISI316	SUS316 or 420J2/AISI420	SUS316/AISI316	SUS316/AISI316

Notes: Following materials supplied on request: 304L S. Steel, 329J1 S. Steel, Hastelloy, 20 Alloy, Monel.

- Standard Materials
- Optional Materials

Optional Features

In order to accommodate your requests, the following features are available.

Inducer Arrangement

Oil Ring Lubricated Bearings

Oil Mist Lubricated Bearings

Water Cooled Bearing Housing/Separate Jacket Type

Water Cooled Bearing Housing/Integrated Jacket Type

Fan Cooled Bearing Housing

Water Cooled Stuffing Box/Separate Jacket Type

Water Cooled Stuffing Box/Integrated Jacket Type

Fan Cooled Bearing Housings

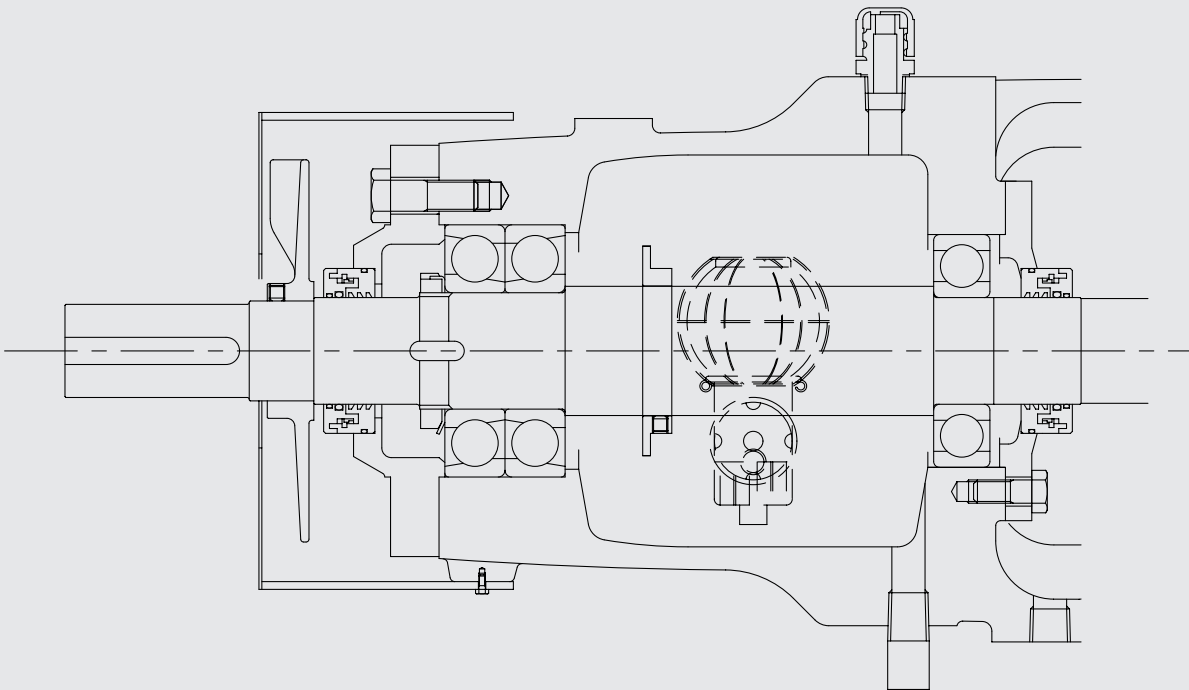

- The fan cooling system can be installed on both end-top and top-top nozzle pumps.
- The fan cooling system improves the operating temperature of the pump under severe conditions, without use of water.

Performance Ranges

Model UCW General Process Pumps

50Hz

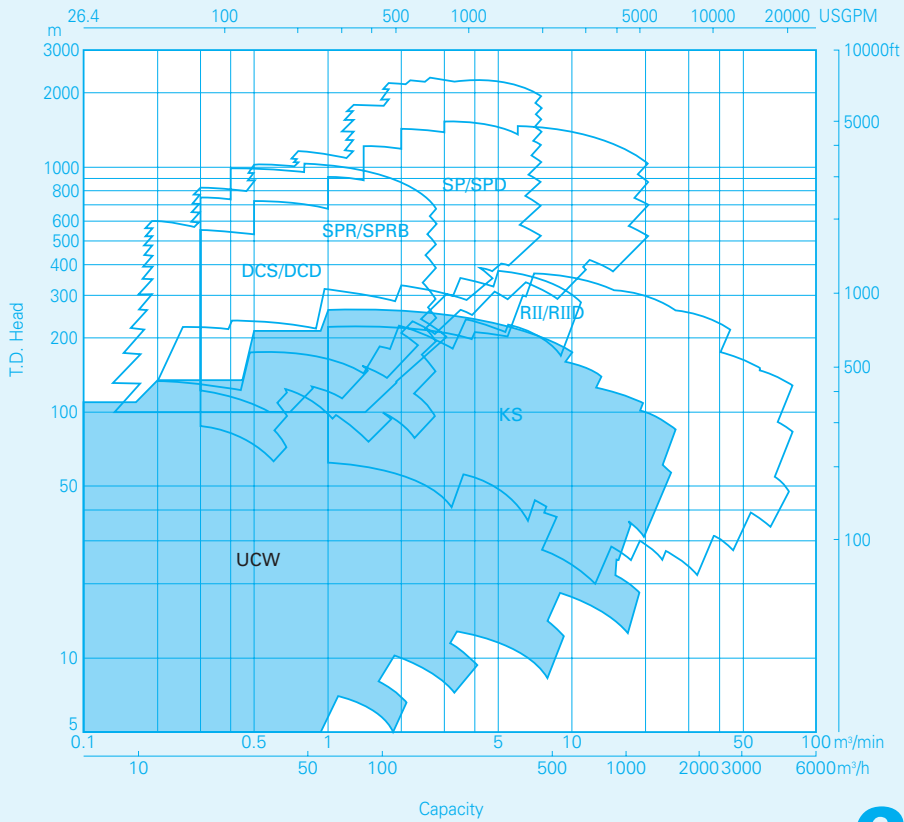

General Process Pumps

60Hz

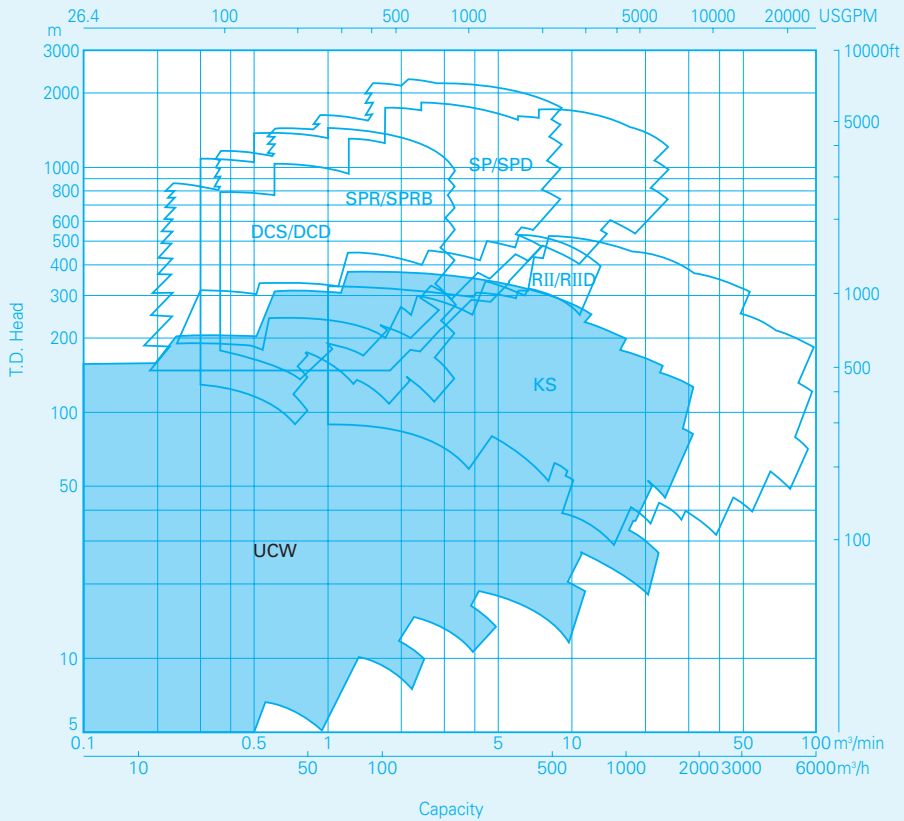

Performance ranges shown on these charts are for preliminary selection only.

Performance Ranges

50Hz

2950min⁻¹

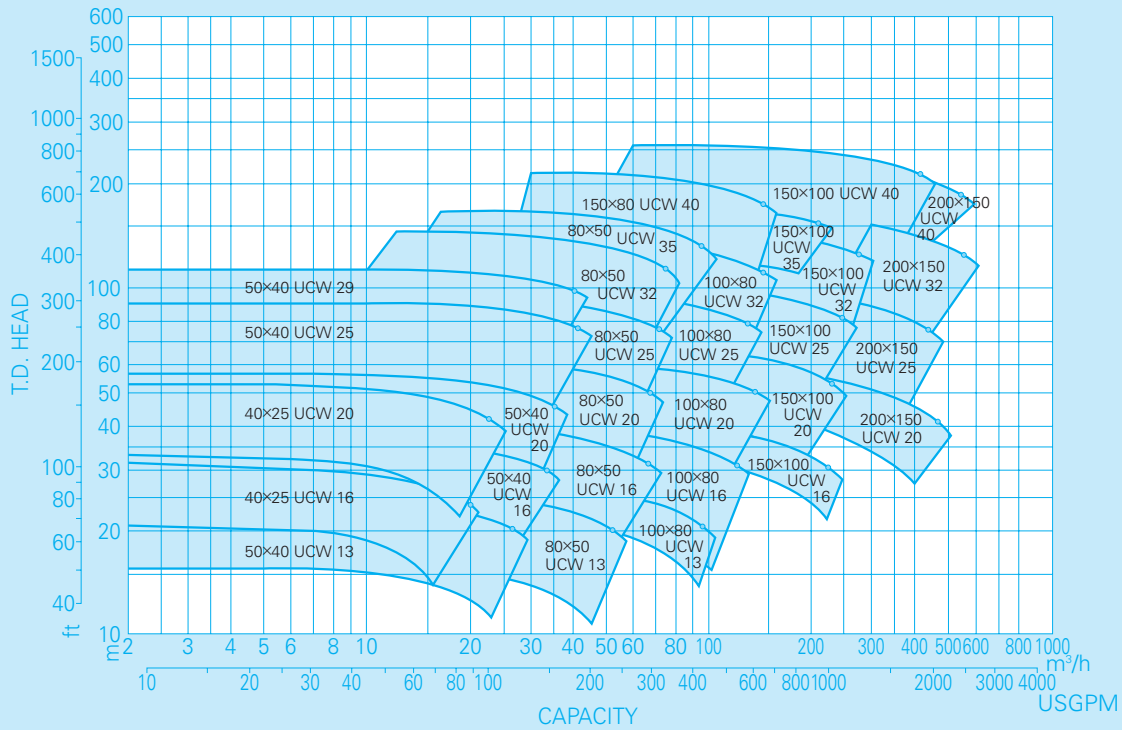

1450min⁻¹

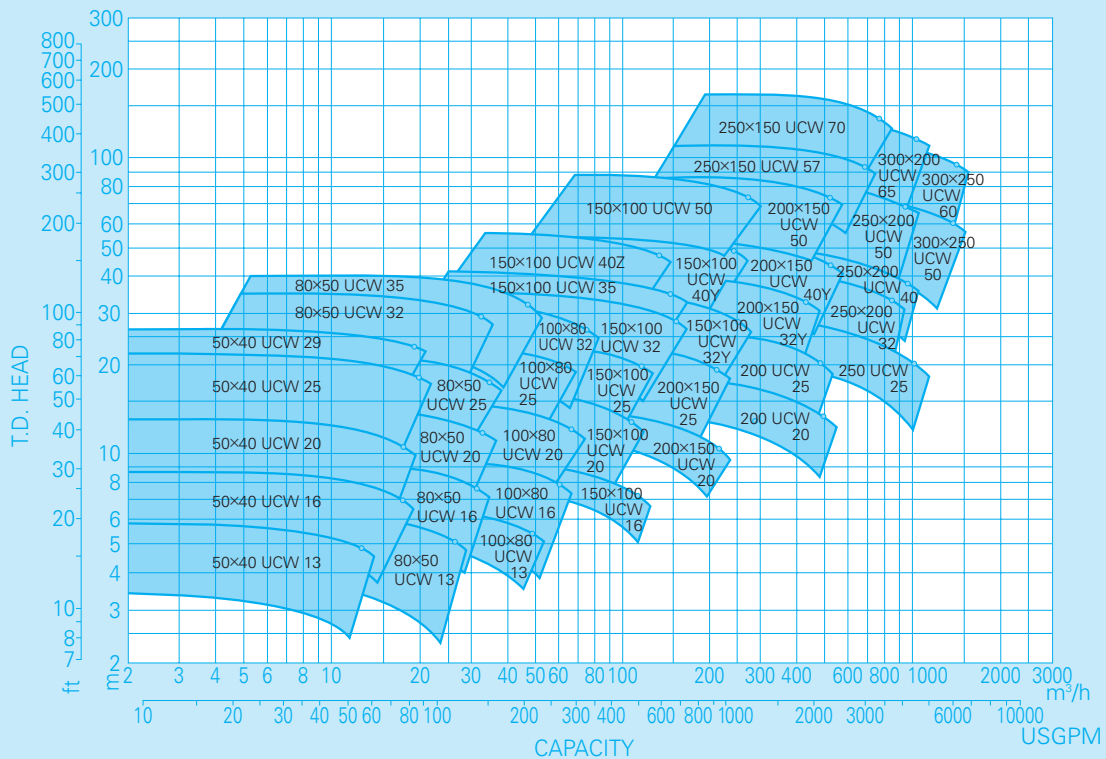

This selection chart is prepared for preliminary selection. Refer to individual performance curves for final selection. O denotes B.E.P. of the performance with an impeller of maximum diameter.

Performance Ranges

60Hz

3550min⁻¹

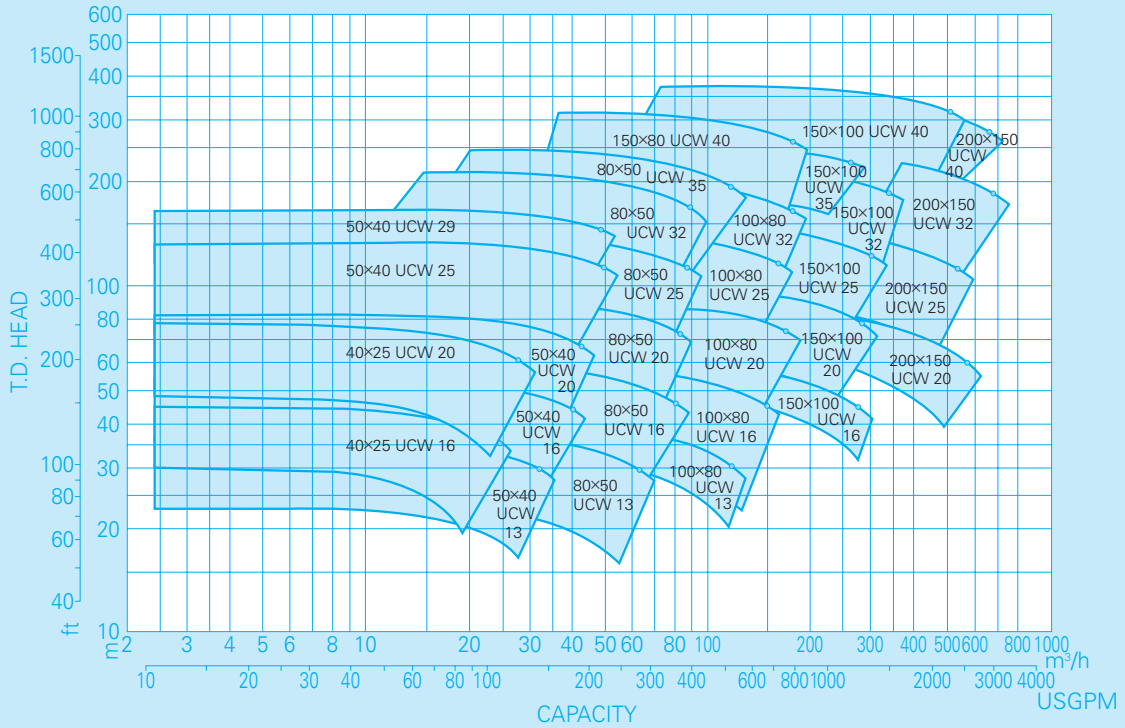

1750min⁻¹

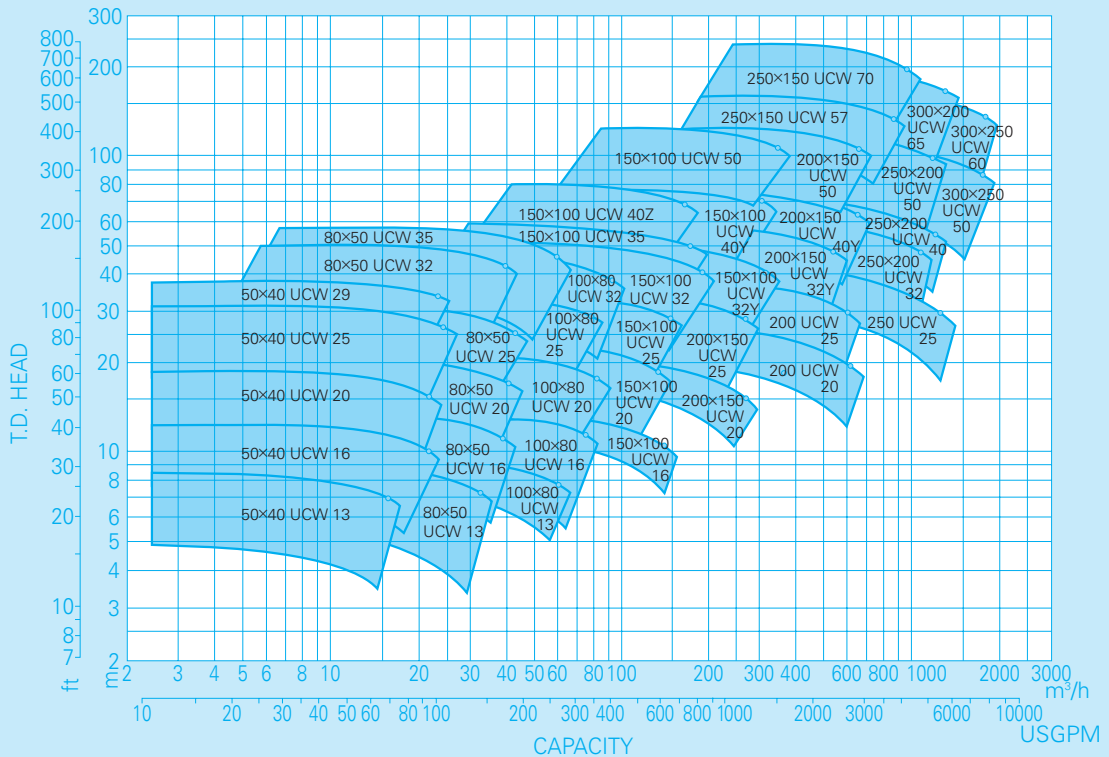

This selection chart is prepared for preliminary selection. Refer to individual performance curves for final selection. O denotes B.E.P. of the performance with an impeller of maximum diameter.

Dimensions

End-Top

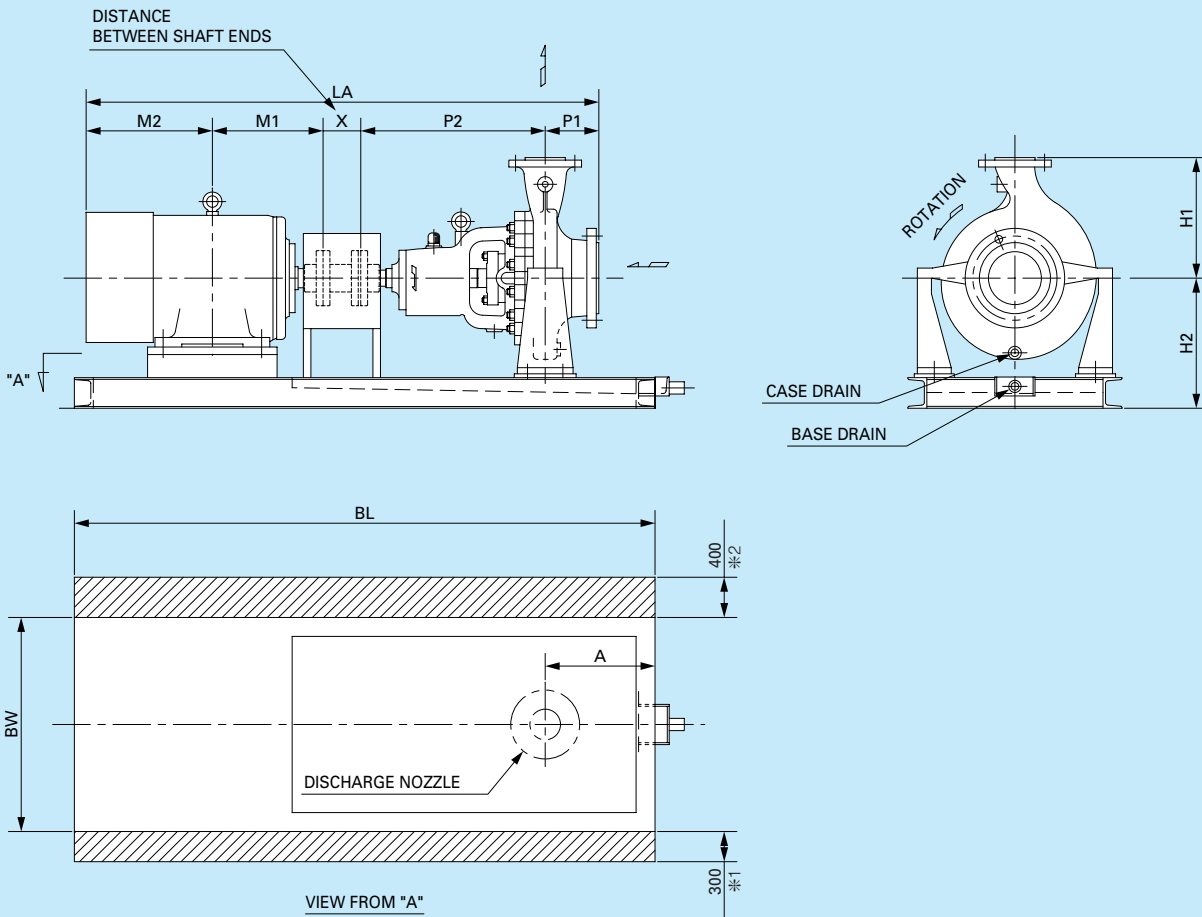

Note

These measurements are approximate and for reference.

*1 When mechanical seal cooler provided, please add 300mm to this BW measurement.

*2 When reservoir provided, please add 400mm to this BW measurement.

Dimensions

End-Top

PUMP MODEL	PUMP AND MOTOR (mm)									BASE (mm)		APPROX WEIGHT (kg)	
	P1	P2	H1	H2	M1	M2	LA	X	A	BL	BW	PUMP	BASE
40x 25UCW16	120	610	240	420	370.5	531.5	1772	140	190	2030	600	135	273
40x 25UCW20	120	610	240	420	370.5	531.5	1772	140	190	2030	600	135	273
50x 40UCW13,13N	135	610	240	420	370.5	531.5	1787	140	190	2040	600	139	274
50x 40UCW16,16N	135	610	240	420	370.5	531.5	1787	140	190	2040	600	141	274
50x 40UCW20	135	610	240	420	395.5	600.5	1881	140	200	2140	600	141	285
50x 40UCW25,25N	140	680	275	485	452.5	600.5	2013	140	200	2270	700	210	416
50x 40UCW29,29N	145	680	290	485	452.5	600.5	2018	140	200	2270	700	222	414
80x 50UCW13	140	610	240	420	370.5	574.5	1835	140	190	2090	600	139	281
80x 50UCW16,16N	140	610	240	420	370.5	574.5	1835	140	190	2090	600	139	281
80x 50UCW20,20N	150	610	240	420	395.5	600.5	1896	140	200	2150	600	147	286
80x 50UCW25,25N	145	680	270	485	452.5	600.5	2018	140	200	2270	700	214	416
80x 50UCW32,32N	170	760	310	505	509.5	545.5	2125	140	240	2380	740	345	442
80x 50UCW35	180	760	340	525	554.5	930.5	2565	140	240	2820	760	420	539
100x 80UCW13	170	680	260	460	402	600.5	1992.5	140	190	2250	600	176	306
100x 80UCW16	170	680	260	460	402	600.5	1992.5	140	190	2250	600	177	306
100x 80UCW20,20N	165	680	260	485	414.5	814.5	2214	140	190	2470	620	182	423
100x 80UCW25,25N	165	760	300	485	509.5	545.5	2120	140	210	2380	700	281	427
100x 80UCW32	170	760	410	565	554.5	930.5	2555	140	260	2805	860	417	615
150x 80UCW40	185	880	470	650	554.5	930.5	2730	180	280	3000	980	623	882
150x 80UCW40S,40U	205	880	400	590	554.5	930.5	2730	180	270	3000	860	620	780
150x100UCW16	190	680	295	525	452.5	930.5	2393	140	240	2660	660	224	511
150x100UCW20	185	760	340	525	554.5	930.5	2570	140	220	2840	720	319	534
150x100UCW25,25N	185	760	340	525	554.5	930.5	2570	140	220	2840	720	363	534
150x100UCW32,32N	195	760	450	650	554.5	930.5	2620	180	300	2890	980	562	902
150x100UCW32Y,32YN	200	760	370	590	452.5	930.5	2523	180	270	2790	870	600	776
150x100UCW35	195	760	450	650	554.5	930.5	2620	180	300	2890	980	590	902
150x100UCW40	200	880	575	690	554.5	930.5	2765	200	310	3030	1120	774	1003
150x100UCW40Y,40YN	205	760	420	610	539.5	575	2259.5	180	270	2530	960	696	727
150x100UCW40Z	200	760	370	590	452.5	930.5	2523	180	270	2790	870	700	776
150x100UCW50	215	880	460	650	614.5	620.5	2510	180	280	2780	990	1090	823
200 UCW20	250	795	430	610	482.5	495	2222.5	200	270	2500	930	700	710
200 UCW25	220	795	480	630	514	515	2224	180	280	2500	970	765	758
200x150UCW20	220	775	380	570	554.5	930.5	2680	200	270	2950	810	404	785
200x150UCW25	220	790	450	590	554.5	930.5	2695	200	270	2970	910	512	856
200x150UCW32	220	880	450	590	554.5	930.5	2785	200	270	3060	910	559	842
200x150UCW32Y	230	790	480	650	614.5	620.5	2435	180	290	2710	1000	876	865
200x150UCW40	230	880	525	690	554.5	930.5	2795	200	300	3070	1120	834	1023
200x150UCW40Y,40N	230	790	480	650	614.5	620.5	2435	180	290	2710	1000	881	865
200x150UCW50,50N	245	980	580	690	614.5	620.5	2640	180	330	2910	1200	1510	1025
250 UCW25	280	815	580	690	614.5	620.5	2530	200	320	2830	1170	860	1056
250x200UCW32	255	880	580	690	614.5	620.5	2570	200	320	2870	1140	1040	1011
250x200UCW40	255	880	580	690	614.5	620.5	2570	200	320	2870	1140	1050	1011
250x200UCW50,50N	250	980	650	730	589	575	2594	200	360	2900	1240	790	1042
250x150UCW57	250	1140	650	780	741	1078	3489	280	370	3790	1305	1900	1414
250x150UCW70	270	1230	780	880	874	1271	3945	300	430	4250	1475	2100	1747
300x250UCW50	300	1165	750	820	874	1271	3890	280	360	4190	1335	2100	1626
300x250UCW60	300	1230	750	840	1095	1593	4510	300	410	4810	1435	2300	1910
300x200UCW65	280	1220	750	880	914	1330	4044	300	410	4350	1455	2200	1758

Note: Dimensions are in mm and for guidance only.

Certified drawings will be provided in all cases of actual construction. Motor dimensions are for a given IEC frame.

Base-plates are sized per our standard, not per the standard base plates in Appendix H of API 610.

On providing on inducer and / or a fan Cooled bearing housing, the certain dimensions differ from those in dicated in the above list.

Dimensions

Top-Top

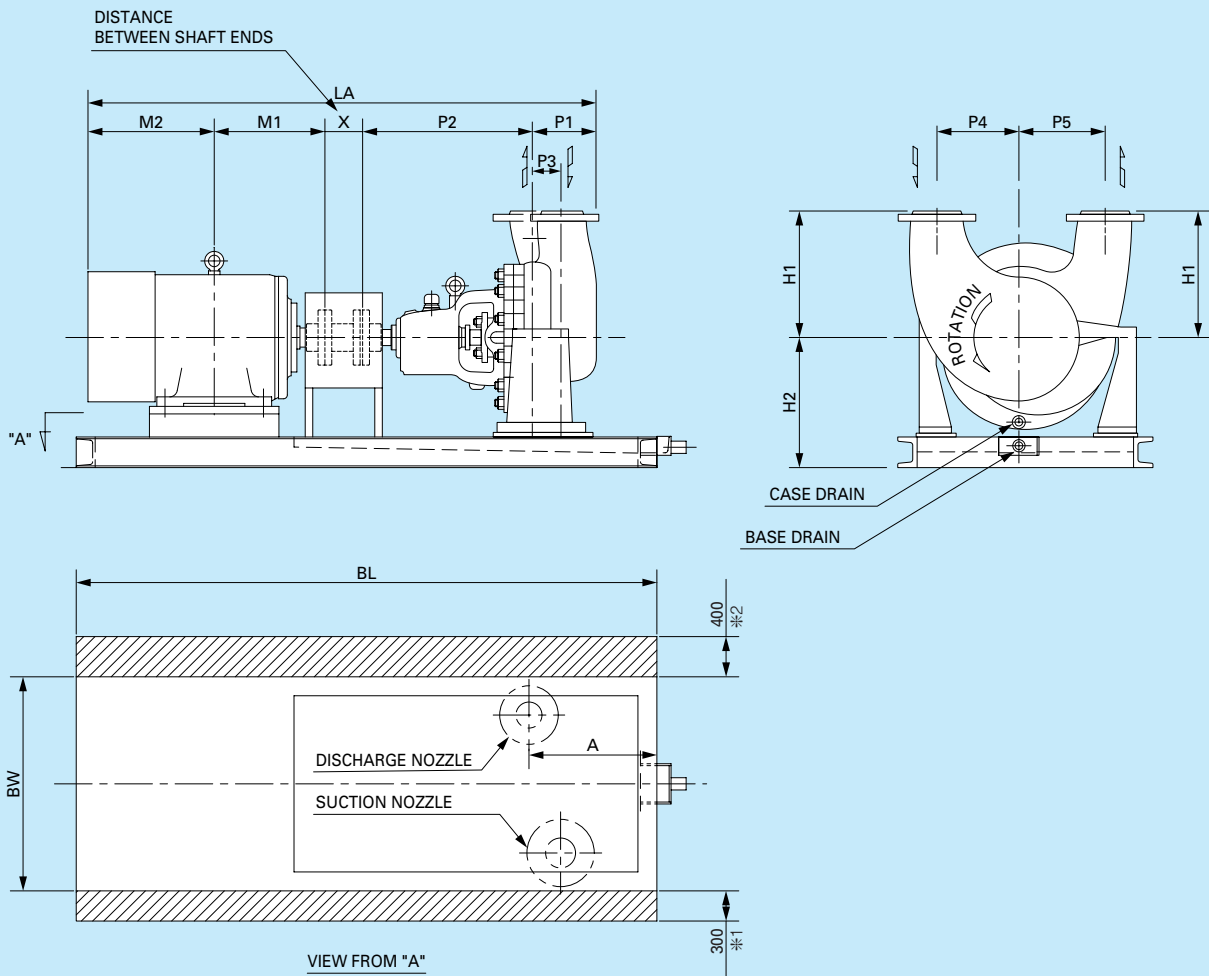

Note

These measurements are approximate and for reference.

*1 When mechanical seal cooler provided, please add 300mm to this BW measurement.

*2 When reservoir provided, please add 400mm to this BW measurement.

Dimension

Top-Top

PUMP MODEL	PUMP AND MOTOR (mm)												BASE (mm)		APPROX WEIGHT (kg)	
	P1	P2	P3	P4	P5	H1	H2	M1	M2	LA	X	A	BL	BW	PUMP	BASE
40x 25UCW16T	96	610	25	90	100	210	420	370.5	531.5	1748	140	190	2030	600	135	273
40x 25UCW20T	100	610	25	80	110	230	420	370.5	531.5	1752	140	190	2030	600	140	273
50x 40UCW13T,13NT	113	610	30	90	100	210	420	370.5	531.5	1765	140	190	2040	600	145	274
50x 40UCW16T,16NT	113	610	30	90	100	210	420	370.5	531.5	1765	140	190	2040	600	150	274
50x 40UCW20T	117	610	30	80	100	230	420	395.5	600.5	1863	140	200	2140	600	150	285
50x 40UCW25T,25NT	125	680	30	80	140	260	485	452.5	600.5	1998	140	200	2270	700	220	416
50x 40UCW29T,29NT	127	680	30	80	155	270	485	452.5	600.5	2000	140	200	2270	700	235	414
80x 50UCW13T	128	610	30	115	110	230	420	370.5	574.5	1823	140	190	2090	600	145	281
80x 50UCW16T,16NT	128	610	30	115	110	230	420	370.5	574.5	1823	140	190	2090	600	145	281
80x 50UCW20T,20NT	141	610	30	105	120	240	420	395.5	600.5	1887	140	200	2150	600	155	286
80x 50UCW25T,25NT	138	680	40	90	145	260	485	452.5	600.5	2011	140	200	2270	700	225	416
80x 50UCW32T,32NT	147	760	40	80	185	350	505	509.5	545.5	2102	140	240	2380	740	360	442
80x 50UCW35T	175	760	60	80	190	320	525	554.5	930.5	2560	140	240	2820	760	500	539
100x 80UCW13T	160	680	60	150	120	260	460	402	600.5	1983	140	190	2250	600	185	306
100x 80UCW16T	160	680	60	150	120	260	460	402	600.5	1983	140	190	2250	600	185	306
100x 80UCW20T,20NT	164	680	50	130	135	250	485	414.5	814.5	2213	140	190	2470	620	190	423
100x 80UCW25T,25NT	173	760	50	120	160	280	485	509.5	545.5	2128	140	210	2380	700	295	427
100x 80UCW32T	177	760	50	90	195	350	565	554.5	930.5	2562	140	260	2805	860	430	615
150x 80UCW40T	195	880	40	110	240	450	650	554.5	930.5	2740	180	280	3000	980	640	882
150x 80UCW40ST,40UT	195	880	40	110	240	450	590	554.5	930.5	2740	180	270	3000	860	640	780
150x100UCW16T	218	680	90	200	145	320	525	452.5	930.5	2421	140	240	2660	660	240	511
150x100UCW20T	203	760	70	170	185	330	525	554.5	930.5	2588	140	220	2840	720	340	534
150x100UCW25T,25NT	203	760	70	170	185	330	525	554.5	930.5	2588	140	220	2840	720	380	534
150x100UCW32T,32NT	207	760	60	150	210	420	650	554.5	930.5	2632	180	300	2890	980	585	902
150x100UCW32YT,32YNT	256	760	80	105	220	355	590	452.5	930.5	2579	180	270	2790	870	625	776
150x100UCW35T	251	760	90	115	240	435	650	554.5	930.5	2676	180	300	2890	980	615	902
150x100UCW40T	238	880	60	95	270	500	690	554.5	930.5	2803	200	310	3030	1120	805	1003
150x100UCW40YT,40YNT	251	760	110	105	245	400	610	539.5	575	2306	180	270	2530	960	720	727
150x100UCW40ZT	214	760	70	105	235	370	590	452.5	930.5	2537	180	270	2790	870	725	776
150x100UCW50T	256	880	110	115	290	430	650	614.5	620.5	2551	180	280	2780	990	1110	823
200 UCW20T	300	795	160	190	240	380	610	482.5	495	2273	200	270	2500	930	730	710
200 UCW25T	282	795	140	190	260	400	630	514	515	2286	180	280	2500	970	800	758
200x150UCW20T	238	775	110	220	195	370	570	554.5	930.5	2698	200	270	2950	810	430	785
200x150UCW25T	245	790	90	190	240	400	590	554.5	930.5	2720	200	270	2970	910	545	856
200x150UCW32T	245	880	90	190	240	400	590	554.5	930.5	2810	200	270	3060	910	585	842
200x150UCW32YT	395	790	120	140	275	450	650	614.5	620.5	2600	180	290	2710	1000	910	865
200x150UCW40T	257	880	100	155	265	500	690	554.5	930.5	2822	200	300	3070	1120	870	1023
200x150UCW40YT,40NT	395	790	120	140	275	450	650	614.5	620.5	2600	180	290	2710	1000	910	865
200x150UCW50T,50NT	312	980	100	120	320	500	690	614.5	620.5	2707	180	330	2910	1200	1540	1025
250 UCW25T	354	815	180	195	310	450	690	614.5	620.5	2604	200	320	2830	1170	940	1056
250x200UCW32T	344	880	185	160	310	560	690	614.5	620.5	2659	200	320	2870	1140	1090	1011
250x200UCW40T	344	880	185	160	310	560	690	614.5	620.5	2659	200	320	2870	1140	1100	1011
250x200UCW50T,50NT	364	980	160	160	355	610	730	589	575	2708	200	360	2900	1240	1840	1042
250x150UCW57T	342	1140	140	130	365	570	780	741	1078	3581	280	370	3790	1305	1950	1414
250x150UCW70T	360	1230	140	120	450	680	880	874	1271	4035	300	430	4250	1475	2150	1747
300x250UCW50T	410	1165	160	180	410	620	820	874	1271	4000	280	360	4190	1335	2150	1626
300x250UCW60T	376	1230	180	150	425	640	840	1095	1593	4594	300	410	4810	1435	2360	1910
300x200UCW65T	364	1220	150	150	430	660	880	914	1330	4128	300	410	4350	1455	2250	1758

Note: Dimensions are in mm and for guidance only.

Certified drawings will be provided in all cases of actual construction. Motor dimensions are for a given IEC frame.

Base-plates are sized per our standard, not per the standard base plates in Appendix H of API 610.

On providing on inducer and / or a fan Cooled bearing housing, the certain dimensions differ from those in dicated in the above list.