



## **QUALITY** Stainless Steel Centrifugal Pump Open Impeller **Type DWO**

### APPLICATIONS

- Industrial dish washer machines
- Washing machines (washing vegetables, meats, fish)
- Water treatment plants
- Painting system cabins
- Dyery machines
- Ecology and food plants

### FEATURES / BENEFITS

- Hydraulic robust construction
- High performance and efficiency design, thus energy saving
- Ebara exclusive patent for hydraulic volute obtained from hydro-forming process
- Low noise
- Compact dimensions
- Passage of solids: maximum diameter of 19mm
- Permanent split capacitor and automatic thermal overload protection for single-phase version



### SPECIFICATION

PUMP		
Liquid Handled	Type of liquid	Clean water
	Temperature [°C]	90 (standard version)
Maximum working pressure	[MPa]	0.8
Construction	Impeller	Open centrifugal type. Passage of solids max ø19mm
	Shaft seal type	Mechanical seal
	Bearing	Sealed ball bearing
Pipe Connection	Suction	G 2
		G 2 1/2 (DWO 300-400)
	Discharge	G 2
Material	Casing	(AISI 304)
	Impeller	(AISI 304)
	Casing cover	(AISI 304)
	Shaft seal	Ceramic/Carbon/NBR (standard)
	Casing cover	(AISI 304)
	Shaft	(AISI 304) (Part in contact with liquid)
	Bracket	Aluminium

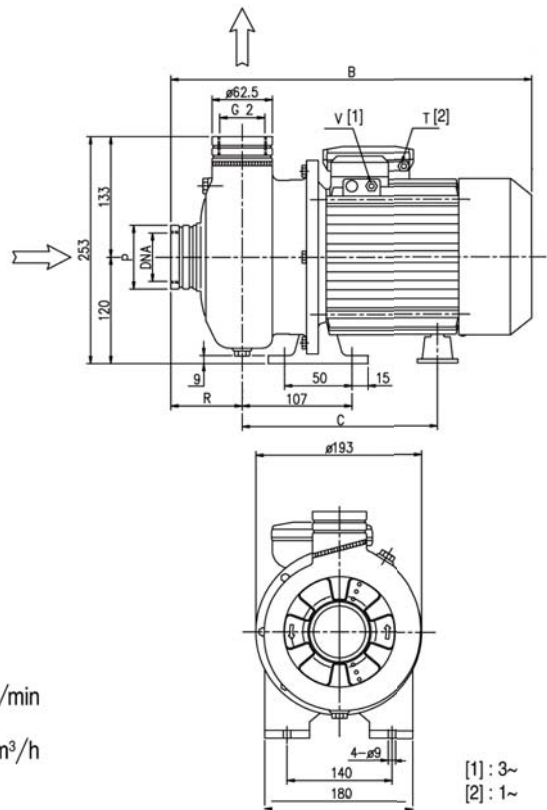
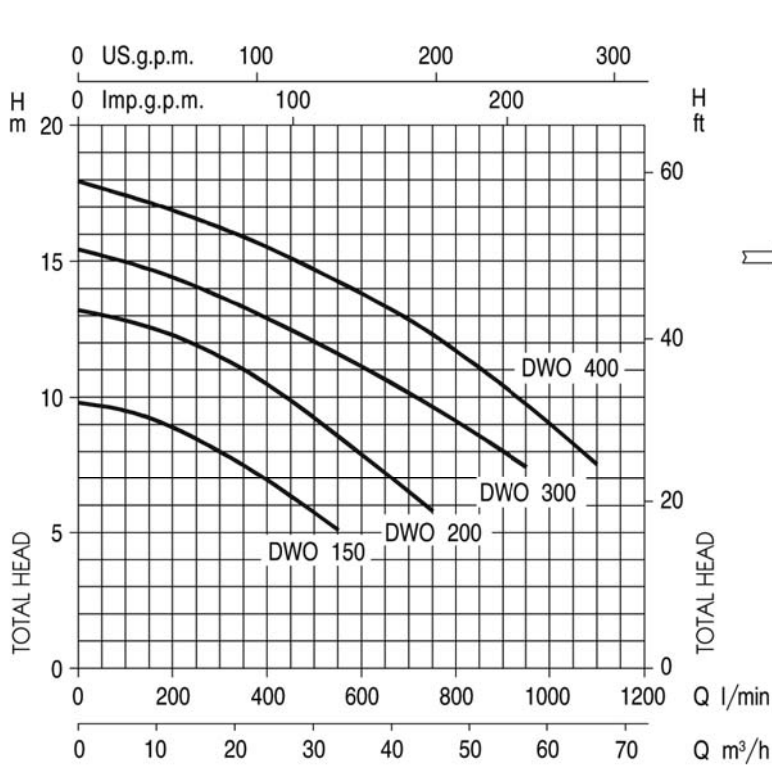

## PERFORMANCE TABLE

Pump type		kW	Capacitor		Absorbed Current (A)			Q = Capacity									
Single-phase 230V 50Hz	Three-phase 230V/400V 50Hz		µF	Vc	Single-phase	Three-phase 230V 400V		l/min m³/h	100	200	300	400	550	750	950	1100	
							H=Total head										
DWO 150M	DWO 150	1.1	31.5	450	6.8	4.4	2.5	9.5	8.9	7.9	6.9	5.1	-	-	-	-	
DWO 200M	DWO 200	1.5	40	450	9.0	6.1	3.5	12.7	12.3	11.5	10.5	8.6	5.8	-	-	-	
-	DWO 300	2.2	-	-	-	8.3	4.8	15	14.5	13.8	12.9	11.7	9.7	7.5	-	-	
-	DWO 400	3.0	-	-	-	11.0	6.4	17.5	16.9	16.3	15.6	14.3	12.4	9.8	7.6	-	

## DIMENSIONAL TABLE

Pump type		Dimensions (mm)							Weight kg	
		B	C	R	ØP	V	T	Ø DNA	1~	3~
Single-phase	Three-phase					3~	1~	G2	1~	3~
DWO 150 M	DWO 150	364	198.5	74	62.5	PG11	PG13.5	G2	13.6	12.6
DWO 200 M	DWO 200	364	198.5	74	62.5	PG11	PG13.5	G2 1/2	15.7	14.4
-	DWO 300	390	215.5	78	80	PG13.5	-	G2 1/2	-	16.9
-	DWO 400	415	240.5	78	80	PG13.5	-	G2 1/2	-	20.0

1~ single-phase  
3~ three-phase

\*All specifications are subject to change without prior notice.



**EBARA Pumps Malaysia Sdn Bhd**  
 No.6, Jalan TP3, UEP Subang Jaya Industrial Park,  
 47620 Subang Jaya, Selangor, Malaysia.  
 Tel : 03-8023 6622 Fax : 8023 9355  
 Email : sales@ebara.com.my  
 Website : www.ebara.com.my



Authorised dealer: