



## QUALITY Stainless Steel Centrifugal Pump Type 2CDX

### APPLICATIONS

- Washing machines
- Water treatment plants
- Air-conditioning plants
- Moderately aggressive fluids pumping
- Air / Humidification treatment plants
- General water supply

### TECHNICAL DATA

- Capacity up to 14.4 m<sup>3</sup>/h
- Total head up to 75m
- T.E.F.C. 2 poles motor
- Insulation class F
- Protection degree IP55
- 1~230V ± 10% 50Hz, 3~230/400V ± 10% 50Hz
- Permanent split capacitor and automatic thermal overload protection for single-phase version
- Thermal protection to be provided by user for three-phase version
- DNA 1" 1/2 for 2CDX200
- DNA 1" 1/4 for other models
- DNM 1"



### FEATURES

- Hydraulic robust construction
- High performances and efficiency
- Integrated volute obtained from hydro-forming process
- Silent
- Compact dimensions



### SPECIFICATIONS

Liquid Handled	Type of liquid	Clean water
	Max temperature [°C]	60 Standard 110 ( 2CDXH and 2CDXHS )
	Min temperature [°C]	-10 standard
Maximum working pressure	[MPa]	0.8
Construction	Impeller	Closed centrifugal type
	Shaft seal type	Mechanical seal
	Bearing	Sealed ball bearing
Pipe Connection	Suction	G 1¼ G 1½ (2CDX200)
	Discharge	G 1
Material	Casing	AISI 304
	Impeller	AISI 304
	Casing cover	AISI 304
	Shaft seal	Ceramic/Carbon/NBR (2CDX) Standard Ceramic/Carbon/FPM (for 2CDXH) SiC/SiC/FPM (for 2CDXHS)
	Shaft	AISI 304 (Wet extension)
	Bracket	Aluminium (up to 1.5kW included) Cast iron (2.2kW and above)
	Diffuser	AISI 304

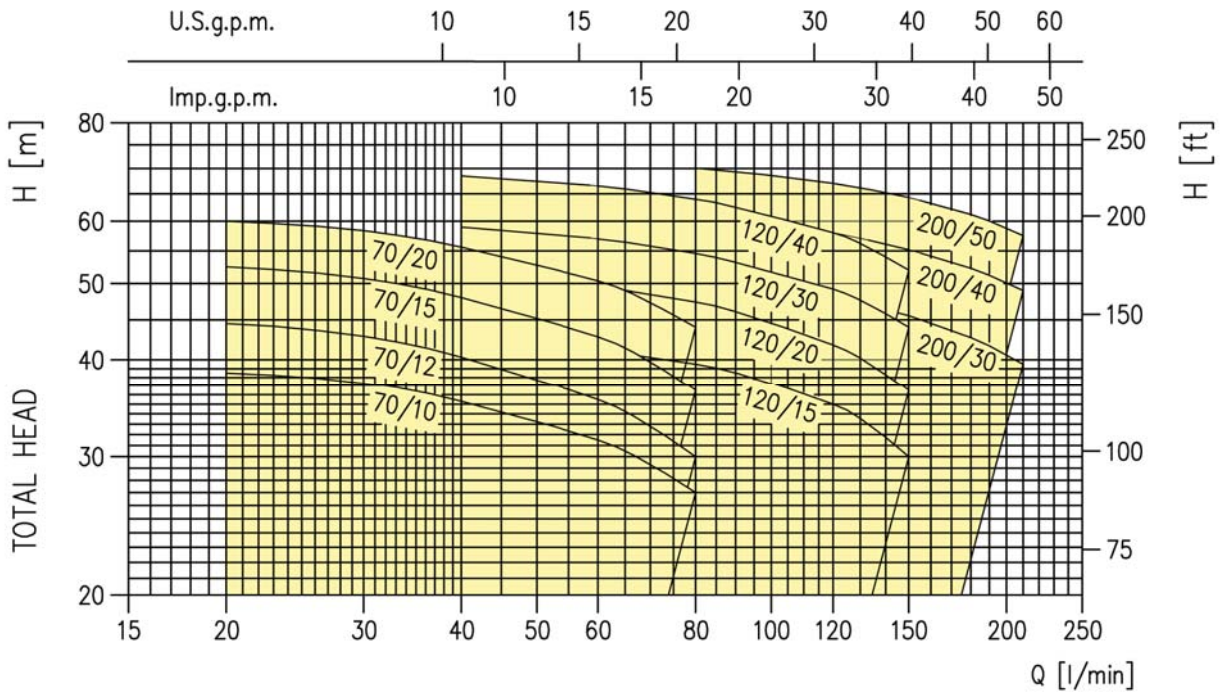

**PERFORMANCE TABLE**

Pump type		Power		Q=Capacity																		
Single-phase	Three-phase	kW	HP	l/min m <sup>3</sup> /h	20	40	60	80	120	150	180	210										
					1.2	2.4	3.6	4.8	7.2	9.0	10.8	12.6	H=Total manometric head in meters									
2CDXM 70/10	2CDX 70/10	0.75	1		38.5	35.3	31.5	27	-	-	-	-	-	-	-	-	-	-	-	-	-	-
2CDXM 70/12	2CDX 70/12	0.9	1.2		44.5	40.3	35.5	30	-	-	-	-	-	-	-	-	-	-	-	-	-	-
2CDXM 70/15	2CDX 70/15	1.1	1.5		52.5	48	42.8	36.5	-	-	-	-	-	-	-	-	-	-	-	-	-	-
2CDXM 70/20	2CDX 70/20	1.5	2		60	55.6	50.4	44	-	-	-	-	-	-	-	-	-	-	-	-	-	-
2CDXM 120/15	2CDX 120/15	1.1	1.5		-	42	41	39.5	35	30	-	-	-	-	-	-	-	-	-	-	-	-
2CDXM 120/20	2CDX 120/20	1.5	2		-	51.5	49.5	47.4	41.8	36.5	-	-	-	-	-	-	-	-	-	-	-	-
-	2CDX 120/30	2.2	3		-	59	57	54.6	49.2	44	-	-	-	-	-	-	-	-	-	-	-	-
-	2CDX 120/40	3	4		-	68.5	66.5	64	58	52	-	-	-	-	-	-	-	-	-	-	-	-
-	2CDX 200/30	2.2	3		-	-	52	50.8	48.1	45.5	42.7	39.5	-	-	-	-	-	-	-	-	-	-
-	2CDX 200/40	3	4		-	-	62.5	61.1	58	55.2	52.3	49	-	-	-	-	-	-	-	-	-	-
-	2CDX 200/50	3.7	5.5		-	-	71.5	70.1	67	64.3	61.2	57.5	-	-	-	-	-	-	-	-	-	-

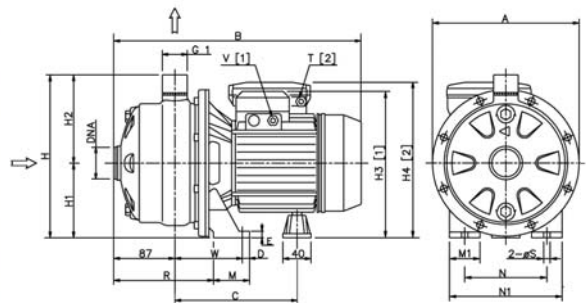

**DIMENSIONAL TABLE**

Pump type	Dimensions (mm)																			
	A	B	C	D	E	H	H1	H2	H3	H4	M	M1	N	N1	R	T	V	W	S	DNA
2CDXM 70/10	208	355	169	12.5	8	229	106	123	206	210	50	38	120	160	142.5	PG11	PG11	93	9	G 1 1/4
2CDXM 70/12	208	355	169	12.5	8	229	106	123	206	231	50	38	120	160	142.5	PG13.5	PG11	93	9	G 1 1/4
2CDXM 70/15	232	385	199	12.5	8	250	118	132	238	251	55	40	140	180	140	PG13.5	PG11	95	9	G 1 1/4
2CDXM 70/20	232	385	199	12.5	8	250	118	132	238	251	55	40	140	180	140	PG13.5	PG11	95	9	G 1 1/4
2CDXM 120/15	208	380	199	12.5	8	229	106	123	226	239	55	40	140	180	140	PG13.5	PG11	95	9	G 1 1/4
2CDXM 120/30	208	380	199	12.5	8	229	106	123	226	239	55	40	140	180	140	PG13.5	PG11	95	9	G 1 1/4
2CDXM 120/40	232	393	210	12.5	8	250	118	132	242	-	65	40	140	180	144	-	PG13.5	109	9	G 1 1/4
2CDXM 200/30	232	394	210	12.5	8	250	118	132	242	-	65	40	140	180	144	-	PG13.5	109	9	G 1 1/4
2CDXM 200/40	208	394	210	12.5	8	229	106	123	230	-	65	40	140	180	144	-	PG13.5	109	9	G 1 1/4
2CDXM 200/50	232	394	210	12.5	8	250	118	132	242	-	65	40	140	180	144	-	PG13.5	109	9	G 1 1/4
-	232	450	236	16	13	250	118	132	255	-	68	50	160	210	144	-	PG16	109	12	G 1 1/2

\*All specifications are subject to change without prior notice.

**EBARA Pumps Malaysia Sdn Bhd**  
 No.6, Jalan TP3, UEP Subang Jaya Industrial Park,  
 47620 Subang Jaya, Selangor, Malaysia.  
 Tel : 03-8023 6622 Fax : 8023 9355  
 Email : sales@ebaracom.my  
 Website : www.ebaracom.my



Authorised dealer: