



QUALITY Stainless Steel Self-Priming Pump Type JESX-JEX

Self Priming Pumps in AISI 304

Self priming electropump made in stainless steel AISI 304 suitable for domestic pressure boosting, small irrigation, gardening, car washing, tanks and pools emptying and pumping clear water in general.

SPECIFICATIONS

- Maximum working pressure: 6 bar
- Maximum liquid temperature:
 - 35°C according EN 60335-2-41 for domestic uses
 - 60°C for other uses

MATERIALS

- Pump body, casing cover, in AISI 304
- Shaft in AISI 303
- Impeller in AISI 304 for JEX, in technopolymer for JESX
- Mechanical seal in carbon/ceramic/NBR

TECHNICAL DATA

- Asynchronous 2 poles motor
- Insulation class F
- Protection degree IP54
- 1~230V \pm 10% 50Hz, 3~230/400V \pm 10% 50Hz
- Permanent split capacitor and automatic thermal overload protection for single-phase version
- Thermal protection to be provided by the user for three-phase version
- DNA 1" for JESX, 1" 1/4 for JEX
- DNM 1"



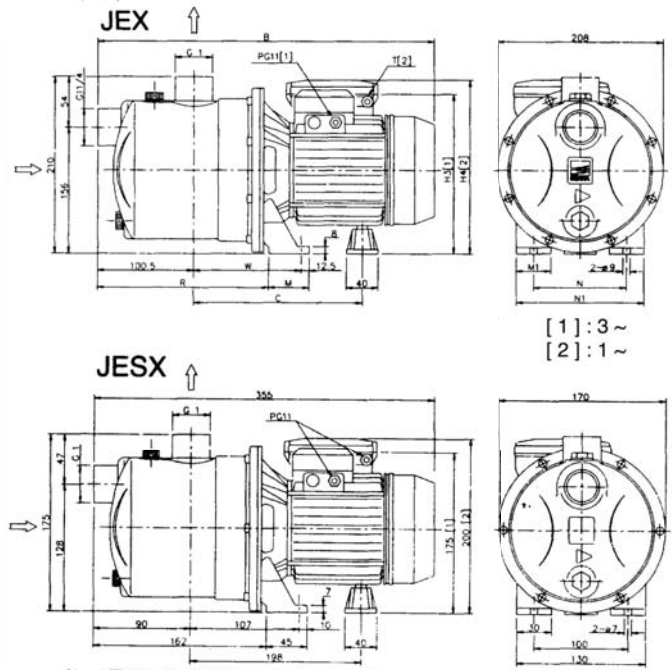
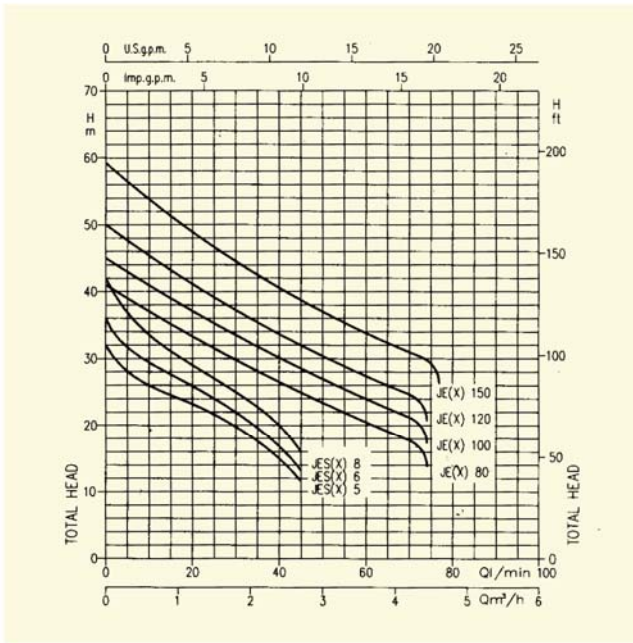

PERFORMANCE TABLE

Pump type		kW	Capacitor		Absorbed Current (A)			l/min m³/h	Q = Capacity									
Single-phase 230V 50Hz	Three-phase 230V/400V 50Hz		µF	VI	Single-phase	Three-phase 230V 400V			5	20	30	40	45	50	60	70	75	
		H=Total head																
JESXM 5	JESX 5	0.37	10	450	2.1	1.5	0.85	28	23	20	15	11.5	-	-	-	-		
JESXM 6	JESX 6	0.44	10	450	2.4	1.9	1.1	31.5	26	22	17	13.5	-	-	-	-		
JESXM 8	JESX 8	0.6	12.5	450	3.0	2.3	1.3	37	29	25	20	16	-	-	-	-		
JEXM 80	JEX 80	0.6	16	450	4.7	3.3	1.9	39	33	29	26.5	25	23.5	20.5	18	-		
JEXM 100	JEX 100	0.75	20	450	6.4	4.5	2.6	43	37	33.5	30	28	27	24	21	-		
JEXM 120	JEX 120	0.88	20	450	6.7	4.7	2.7	47.5	41	37	34	32	30.5	27.5	24.5	-		
JEXM 150	JEX 150	1.1	31.5	450	8.0	5.6	3.3	56	49	44.5	40.5	38.5	37	34	31	29.5		

DIMENSIONAL TABLE

Pump type		Dimensions (mm)										Weight kg	
		B	C	H3	H4	M	M1	N	N1	R	T		W
Single-phase	Three-phase												
JEXM 80	JEX 80	417	230	206	215	50	38	120	160	206	PG11	143	10.5
JEXM 100	JEX 100	417	230	206	215	50	38	120	160	206	PG11	143	10.8
JEXM 120	JEX 120	417	230	206	215	50	38	120	160	206	PG11	143	11.5
JEXM 150	JEX 150	445	250	216	240	55	40	140	180	203.5	PG13.5	145.5	14.1

*All specifications are subject to change without prior notice.



EBARA Pumps Malaysia Sdn Bhd
 No.6, Jalan TP3, UEP Subang Jaya Industrial Park,
 47620 Subang Jaya, Selangor, Malaysia.
 Tel : 03-8023 6622 Fax : 8023 9355
 Email : sales@ebaracom.my
 Website : www.ebaracom.my



Authorised dealer: