



## Submersible Dewatering Pump

High Capacity Series \_\_\_\_\_ Type EU

*These models are designed to be used for major dewatering jobs, particularly when bigger volume of water is required. They have extremely high capacity and are excellent in heavy-duty oriented conditions.*

### APPLICATIONS

Drainage of Sumps pits, Quarries, Minings, Cellars, Dams, Harbour & Agricultural Irrigation Projects, Tunnels, Caisson Dewaterings, Reclaiming Operations, Power Station Constructions, Waste, Storm or Emergency Water Removal, Contractors & Rental Companies, etc.

### FEATURES

- **MOTOR PROTECTOR**

Incorporating Miniature Thermal Protector (MTP) and Infiltrative Water Detector (WD) in the pump body to protect the motor from electric and mechanical troubles. Both in combination with the operating panel (at extra cost) equipped with Electromagnetic Contactor (MC) Infiltrative Water Detector Relay Set (WD-X) and Thermal Relay, the pump assures perfect and safety - minded motor protection. In case water infiltrates the motor housing or the temperature of motor winding rises maximum degree, WD fitted immediately beneath the motor compartment or the MTP activates the MC with WD-X or THR in order to cut off the electric supply. 200EU511, 200EU515 & 200EU522M built-in "Auto-Cut", auto-reset type thermal protector, which are equipped to protect the motor against presumable electric and thermal troubles at your work-sites. 200EU522, 250EU522, are equipped with "Auto-Cut" for voltage 200-220V only.

- **MOTOR**

The motors are well designed and selected to demonstrate higher Motor efficiency and torque. By the same token, six pole motors are integrated for 350EU537 while four pole motors are used for other models to meet the required high capacity. The motors are well designed to demonstrate higher motor efficiency and torque.



## FEATURES

- SHAFT SEAL**

Double mechanical seals are cooled and lubricated by oil bath to ensure reliable sealing effect and steady services at heavy-duty dewatering sites.

- IMPELLER & CASING**

The open impeller made of hardened High Chrome Alloy in heavy gauge body gives high efficiency in pumping performance in combination with assorted casing as well as providing admirable resistance in the water containing abrasive solid particles.

## SPECIFICATIONS

- Discharge Dia. : 200 - 350mm
- Total Head : 10 - 27m
- Capacity : 2 - 14m<sup>3</sup>/min
- Motor Output : 11 - 55kW

## PERFORMANCE CURVE

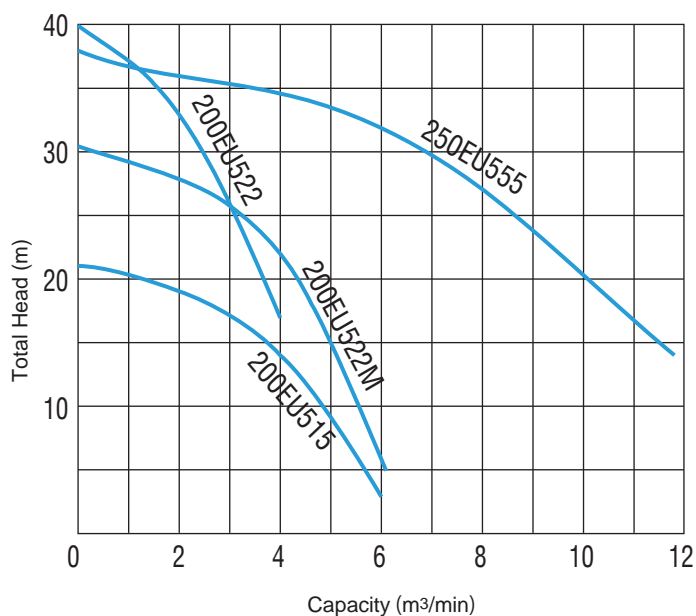
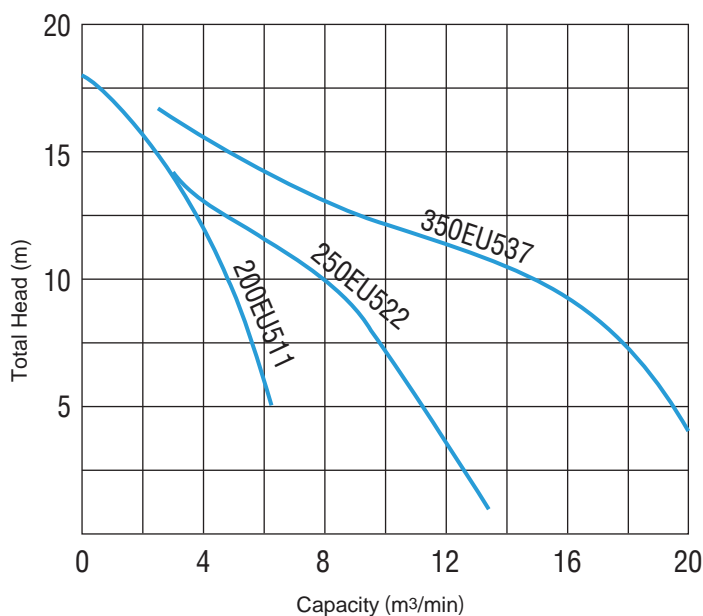

Model	Nominal diameter (mm)	Output (kW)	Ph/Hz/V	Total Head (m)	Capacity (m <sup>3</sup> /min)	Max. Head (m)	Outer dimension (mm)		Weight (kg)
							Max. diameter	Height	
200EU511	200	11	3Ph/50Hz/ 380-415V	10	4.0	18	455	940	177
200EU515	200	15		14	4.0	21	455	940	227
200EU522	200	22		20	2.0	40	540	1110	360
200EU522M	200	22		22	4.0	30	540	1158	440
250EU522	250	22		10	8.0	16	540	1080	355
350EU537	350	37		10	14.0	17	670	1435	730
250EU555	250	55		27	8.0	38	670	1475	700

SECTIONAL VIEW

200EU511

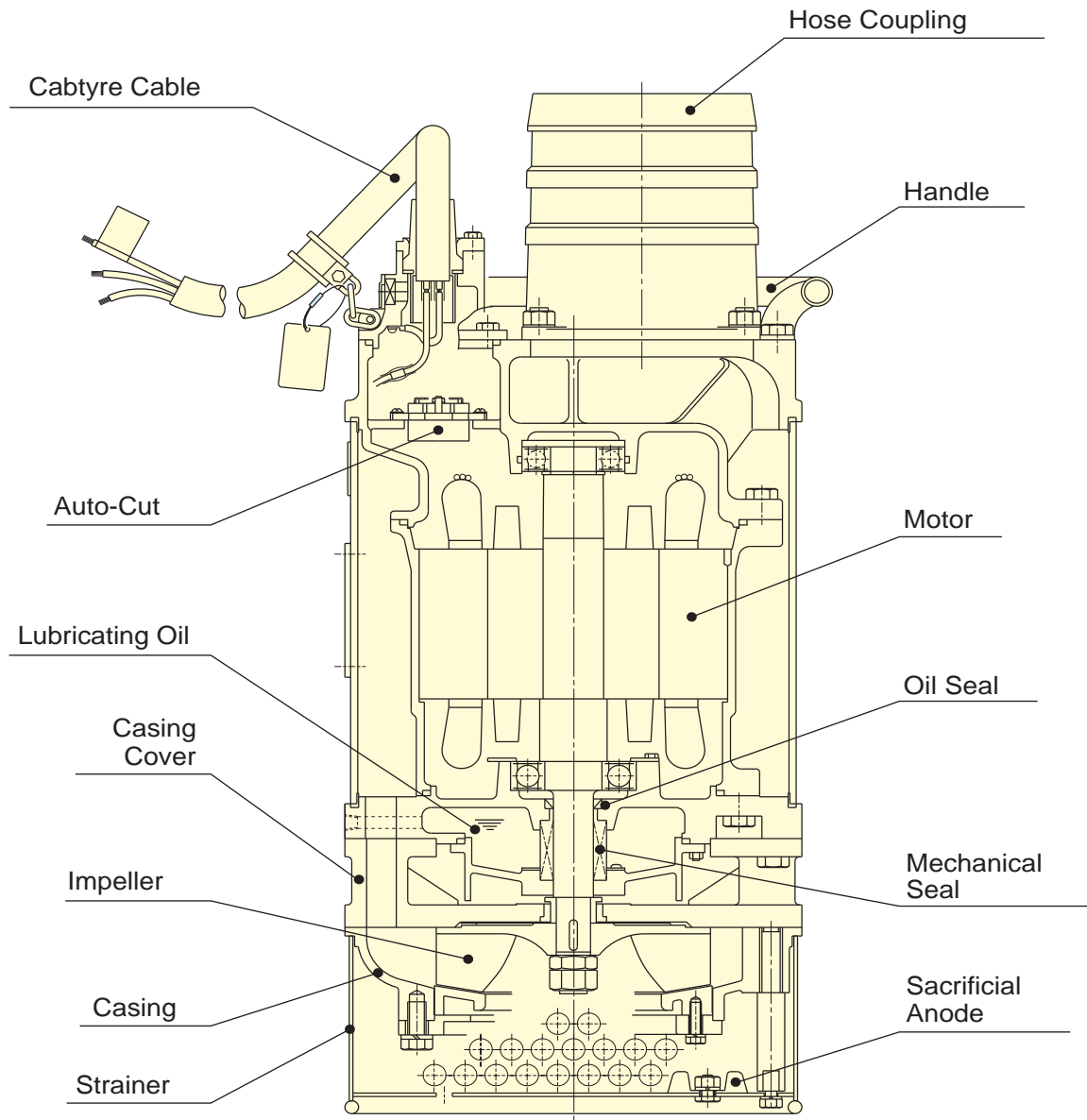

## DIMENSION

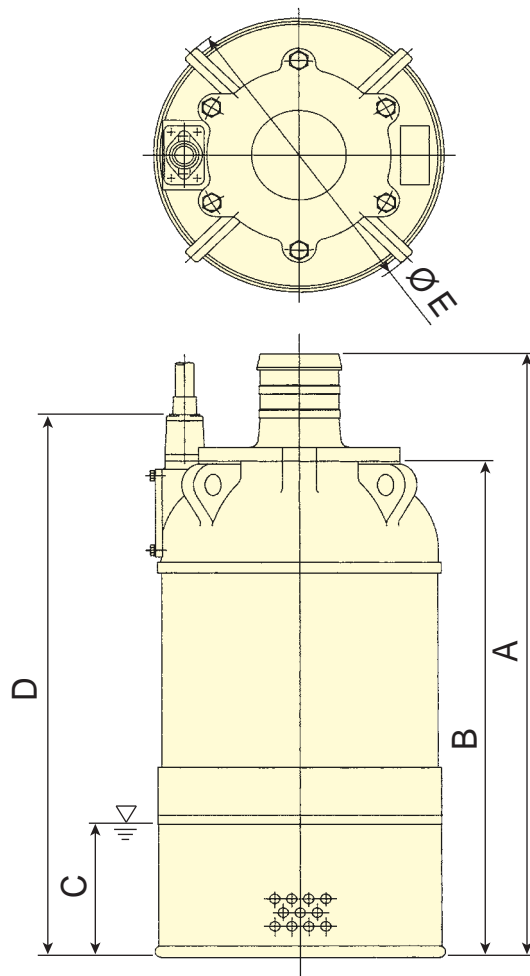

C : Minimum Water Level

Unit : mm

Model	Pump				
	A	B	C	D	E
200EU511	940	-	250	805	455
200EU515	975	-	250	805	455
200EU522	1130	-	250	1015	540
200EU522M	1158	-	250	1015	540
250EU522	-	1000	350	1085	540
350EU537	-	1310	400	1475	670
250EU555	-	1270	350	1435	670

Note : Flange discharge type is available.

\* Dimensional details are provided for reference only.

\* All specifications are subject to change without prior notice.



**EBARA Pumps Malaysia Sdn Bhd**  
 6, Jalan TP3, UEP Subang Jaya Industrial Park,  
 47620 Subang Jaya, Selangor, Malaysia.  
 Tel : 03-8023 6622 Fax : 03-8023 9355  
 Email : sales@ebara.com.my  
 Website : www.ebara.com.my



Authorized dealer: